

College Physics II

Lab 8: RC Circuits

Peter Rolnick with Taner Edis

Spring 2017

Introduction

Consider the circuit shown. (Consult section 23.7 in your textbook.) If left for long enough, the charge on the capacitor will increase from $q = 0$ to $q = CV_0$. During that time, q will change with time according to the relation

$$q(t) = CV_0 \left(1 - e^{-\frac{t}{RC}}\right)$$

while the capacitor is being charged. The voltage difference between the plates of the capacitor will be

$$V(t) = \frac{q}{C} = V_0 \left(1 - e^{-\frac{t}{RC}}\right)$$

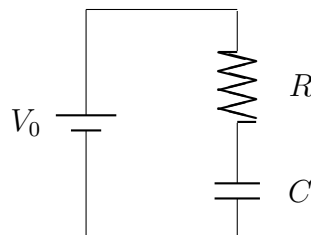

If we now quickly disconnect the voltage source, and allow the capacitor to discharge across the resistor, q will decrease—quickly at first, then more slowly—according to the relation

$$q(t) = CV_0 e^{-\frac{t}{RC}}$$

ACTIVITY 1: THE RC CIRCUIT

while being discharged, and the voltage difference between the plates of the capacitor will be

$$V(t) = \frac{q}{C} = V_0 e^{-\frac{t}{RC}} \quad (1)$$

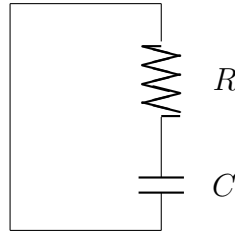

This is what you will observe on the oscilloscope as we alternately charge and discharge the capacitor. This is accomplished by using a square wave voltage, which is equivalent to attaching and disconnecting a battery: when in square wave mode, the function generator alternates between $V = V_0$ and $V = 0$. The capacitor will charge when the square wave is at $V = V_0$, discharge when the square wave is at $V = 0$, charge, discharge, ...

Activity 1: The RC Circuit

First, you will see a capacitor in an RC circuit charging and discharging, and directly compare what you see with the voltage source which is being turned on and off. For the set-up we will be using, the time to charge and discharge is so fast that the only way you can see it is using an oscilloscope. You will observe how the shape of the charging and discharging curves vary as a function of the resistance in the circuit. You will also see that if you don't give the circuit enough time between when the voltage source turns on and off, the circuit will not have time to completely charge or to completely discharge, resulting in a decrease in amplitude.

Second, you will take measurements directly off the discharge curve on the oscilloscope, and use those data to make a graph, the slope of which is $-1/RC$. You will also calculate $-1/RC$ using the nominal values of the resistor and the capacitor, and compare that with your results from the graph.

ACTIVITY 1: THE RC CIRCUIT

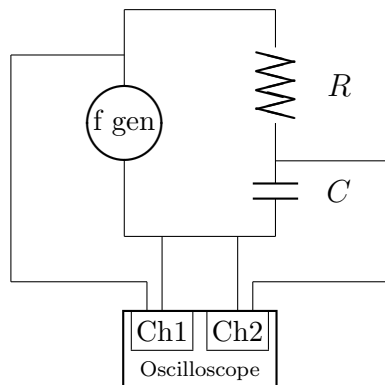

Set up the circuit shown. The oscilloscope should be set to view both traces; be sure you know which trace is which voltage: Ch1 is the function generator and Ch2 is the capacitor. Set the function generator to square wave, about 1000 Hz, and any voltage greater than zero. The R shown in the diagram is actually a series combination of the external resistance (the decade resistance box) and the internal resistance of the function generator

$$R = R_{\text{external}} + R_{\text{internal}}$$

$R_{\text{internal}} = 600 \, \Omega$ for the Pasco and Hewlett-Packard function generators, $R_{\text{internal}} = 50.0 \, \Omega$ for the Tektronix function generators. The capacitor is $.0100 \, \mu\text{F}$, that is, $1.00 \times 10^{-8} \, \text{F}$.

Some precautions so the equipment survives:

- Make sure that the power supply is set on the 2 V peak-to-peak range. The 20 V range could result in too much power dissipation—more than the power rating of some of the circuit elements.
- Never allow any current to flow through the variable resistor when it is set to zero resistance. Again, this could result in too much power dissipation—more than the power rating of some of the components of the variable resistor.
- Make sure that the negative (or ground) connections from Ch1 and Ch2 both go to the same point between the signal generator and the capacitor. Otherwise, you will have a ground loop problem. The negatives of both Ch1 and Ch2 are connected to each other inside the oscilloscope, so they must be connected to the same place in the circuit.

ACTIVITY 1: THE RC CIRCUIT

Now, do the following:

1. Draw a picture of the Ch1 trace as compared to the Ch2 trace for a range of values for R from $3000\ \Omega$ to $15,000\ \Omega$, noting the difference and similarities between the two traces for different values of R .
2. Notice, for a given set of values for R , C , and signal amplitude, what happens to the Ch2 trace as the frequency gets very high. At very high frequencies there should be hardly any amplitude. Ask yourself why. Make a rough estimate of the frequencies at which the amplitude is about 90% of the original, and where it is 10% of the original.
3. For a value of R where it looks like you get a nicely visible exponential decay curve, turn off Ch1 and make the trace of Ch2 as large as possible. Call the peak value V_0 ($t = 0$ when $V = V_0$), and as the voltage decays, the value of V will become an increasingly smaller fraction of V_0 . Record about 5 to 10 points along the decay curve (*not* the charging curve!) from $V = V_0$ to V very near zero. Your data points should not be evenly spaced along the horizontal axis; choose more of the points from the region of the curve where V is changing at the greatest rate. Since you are interested in values of V/V_0 and not V , you do not have to measure the vertical axis of the oscilloscope in Volts—number of divisions will be fine. However, measurements off the horizontal axis of the oscilloscope must be in seconds. To get a value for $-1/RC$ from these data, we need to consider the exponential decay expressed in equation (1). With a little algebra, we get:

$$\ln\left(\frac{V}{V_0}\right) = -\frac{t}{RC}$$

This means that if you graph $\ln(V/V_0)$ (vertical on your graph) versus t (horizontal), you will get a line with slope $-1/RC$. Don't forget to include the internal resistance in your data and calculations. See how your result for $-1/RC$ compares with that calculated directly from the nominal values of the resistor and capacitor. Be sure you make this graph and analyze it before you leave the lab.

To hand in for activity 1

- Qualitative drawings of Ch1 and Ch2 traces, noting $R = R_{\text{external}} + R_{\text{internal}}$ for each drawing.
- Rough experimental estimate of frequency at which amplitude in Ch2 noticeably decreases, and explanation.
- all data (R_{internal} , R_{external} , C ; V and V_0 (in numbers of vertical divisions), t (in seconds),
- all quantities initially calculated from those data: R , t (in s), $\ln(V/V_0)$,
- graph of $\ln(V/V_0)$ versus t , and the slope of that graph,
- comparison of slope of above graph with $-1/RC$, using nominal values.

Postscript

As you can see from this lab, the oscilloscope can be used to find both qualitative and quantitative details of a circuit. It might be used to troubleshoot a broken television set, or a broken component of a stereo system, by looking at a portion of the circuit and seeing if it is behaving the way it is supposed to.

You also noticed that an RC circuit will not respond to a periodic signal if the frequency is significantly higher than $1/RC$. Thus an RC circuit is sometimes called a low pass filter, since it blocks high frequency signals. Such a circuit might be useful if you wanted to filter out high frequency static from a radio signal.